

Executive Summary
For

Proposed Redevelopment under 33/7 of D.C
Reg.
At
C.S no. 525 of Mazgaon Division in E ward,
Mumbai Maharashtra.

Proposed By
M/s. Sumer Buildcorp Pvt. Ltd.

Mumbai is the financial capital of INDIA as well as one of the highest populated city. In the last decade there is a rapid increment in residential and business/commercial development due to shifting of industries out of Mumbai. It is to be mentioned here that major development of Mumbai is in residential and business/commercial project field.

Buildings and chawls with atrocious living in Mumbai have been dilapidated and hence it is essential to develop these slums, chawls which are affected by CRZ.

The development of such buildings and chawls can be done as per CRZ norms of 2011.

1 PREAMBLE

The proposed project is a development under 33(7). The project site has currently residential and industrial units which have been categorized as cessed & dilapidated structure under category “A + A1”, situated at plot C.S no. 525, of Mazgaon Division at Junction of Barrister Nath Pai Marg & Mathar Pakhadi Road Mazgaon Mumbai. The said project also comes under the purview of EIA notification 2006 as the total proposed built up area including Fungible and area Free of FSI is 1,42,502.88 Sq.m

2 APPLICABILITY OF CRZ NOTIFICATION

According to Para 4 (d) of CRZ notification 2011, The proposed project area falls under CRZ II as per the CZMP of Mumbai. The area is well developed with infrastructure facilities in place. Project Proponent also commissioned Institute of Remote Sensing (IRS), Anna University, Chennai, one of the MoEF approved agencies, to carry out the CRZ demarcation of the project site afresh. The IRS report also reconfirms that the project site falls under CRZ II. Since this is an individual redevelopment project in CRZ II area, it is mandatory to hold Public Hearing as per clause 5(c) 2(d) (4), before it can be considered by Maharashtra Coastal Zone Management Authority.

3 IDENTIFICATION OF PROJECT PROPONENT

Table 1 Details of Contact Person

#	Particular	Details
1	Name of Developer	M/s. Sumer Buildcorp Pvt Ltd.
2	Name of Contact person	Mr. Kunal Gosain
3.	Designation of Contact person	Director
4.	Contact No	+91 7400400636
5.	Email	kunalgosain@sumergroup.co.in
6.	Address	201, Commerce House, Nagindas Master Road, Fort, Mumbai-400001

4 LOCATION

The proposed project admeasuring about 38,881.58 sq. m. of plot area is situated on C.S no. 525, of Mazgaon Division at Junction of Barrister Nath Pai Marg & Mhatar Pakhadi Road Mazgaon Mumbai. Geographically it is located on Latitude 18°58'22.42"N & Longitude 72°50'38.32"E.

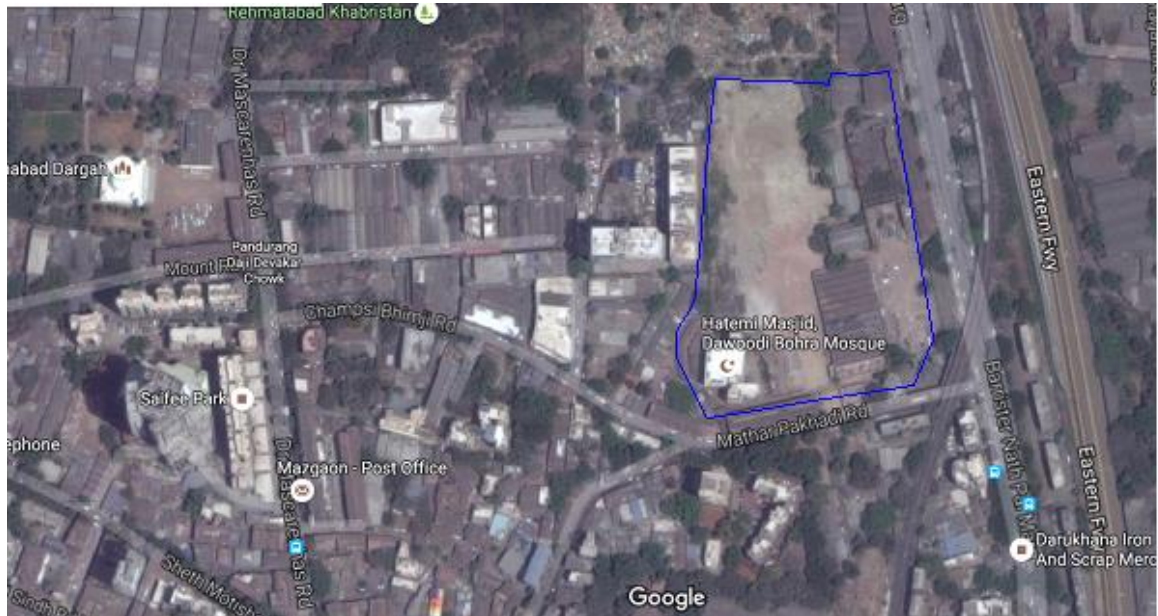

Fig. 1: Location of Proposed Project

5 DESCRIPTION OF PROJECT SITE

The land covered through the small scale industrial units most of the units are now closed Owners of these units currently residing on the plot. The site lies in the CRZ II area as per the demarcation plan on scale of 1:4000 prepared by Institute of Remote Sensing, Anna University, Chennai.

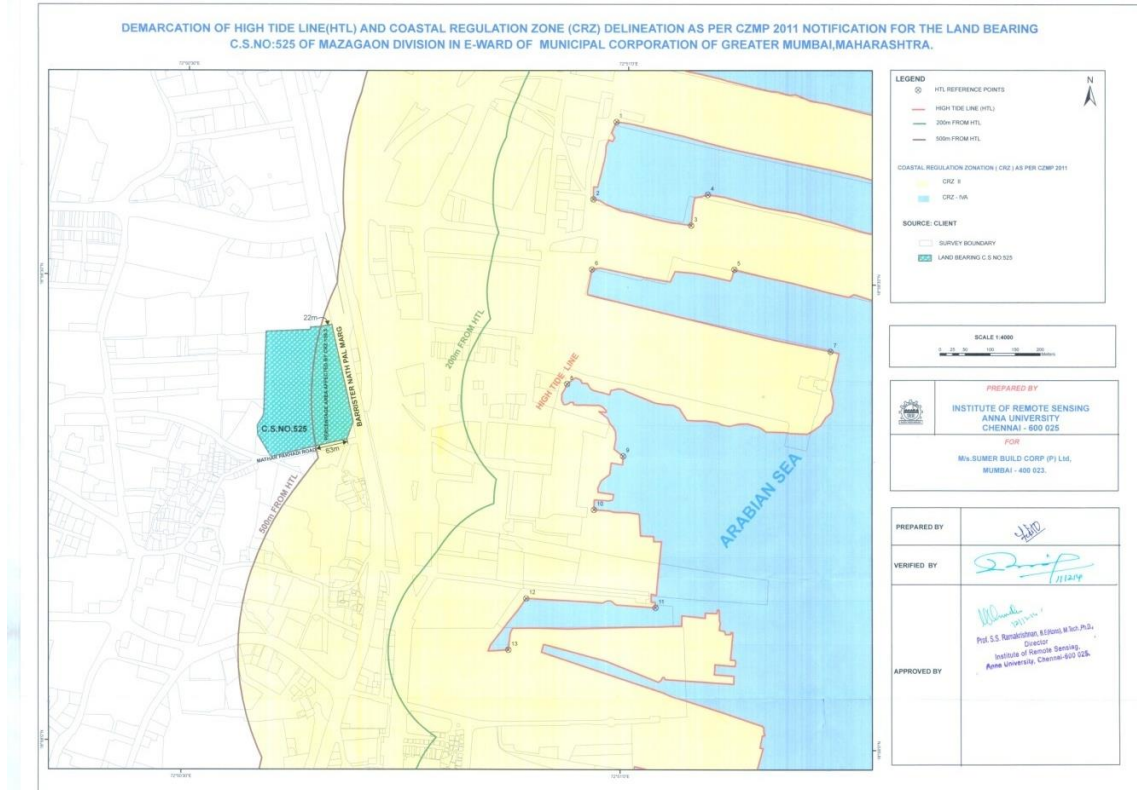

Fig. 2: Showing Location of Proposed Project on CZMP Map

6 PROJECT DESCRIPTION

The proposed project is having three buildings

Building 1 (Sale): 3 Wings

Wing A: Gr + 1st Podium + 2nd podium (stilt) + 1st to 20th Upper floor + Fire Check Floor

Wing B: Gr + 1st Podium + 2nd podium (stilt) + 1st to 20th Upper floor + Fire Check Floor

Wing C: Gr + 1st Podium + 2nd podium (stilt) + 1st to 20th Upper floor + Fire Check Floor

Building 2 (Proposed Masjid): Pt ST + Pt Podium + Part 1st + 2nd + to 4th Floor

Building 3 (Rehab for CESS tenants and MHADA surplus): Gr + Service Floor + 17 Floors

Tenements: Sale - 456 No's Rehab and MHADA – 115 Shops – 11.

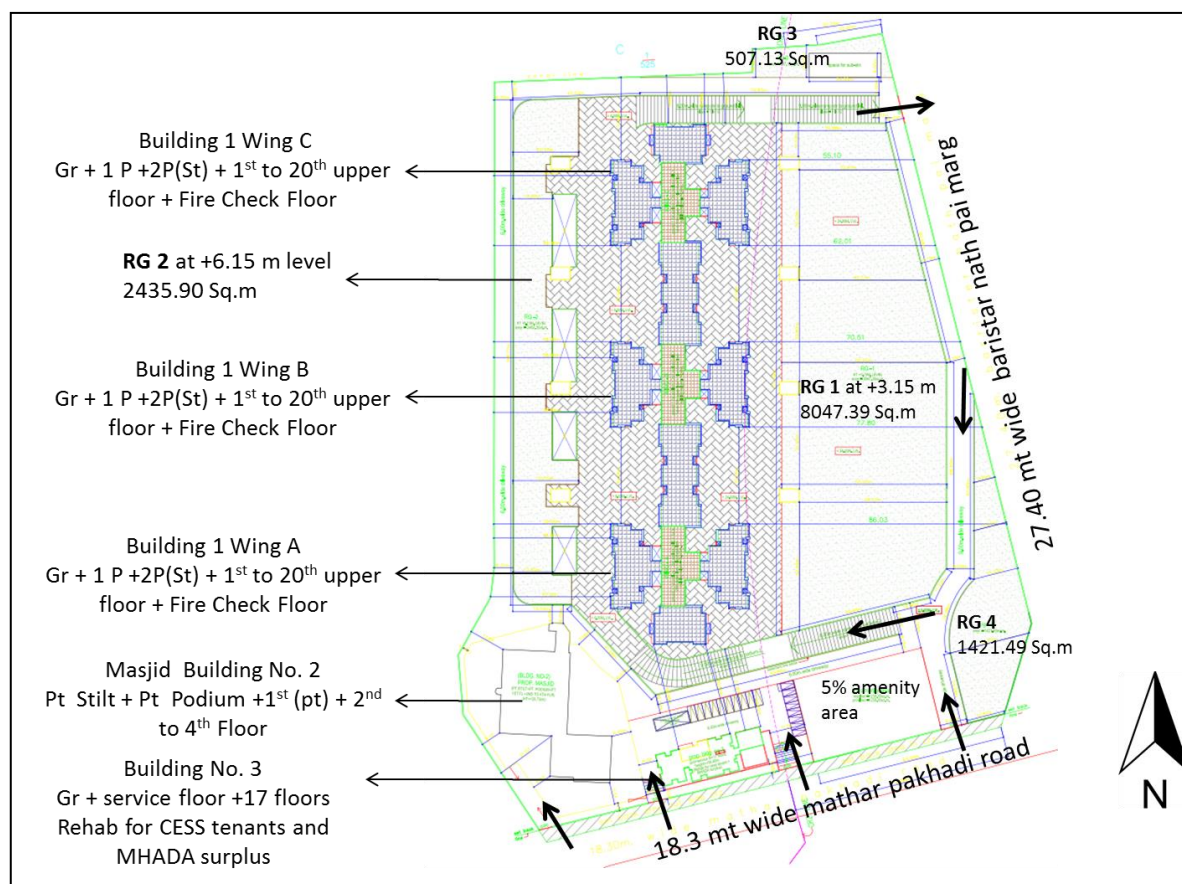
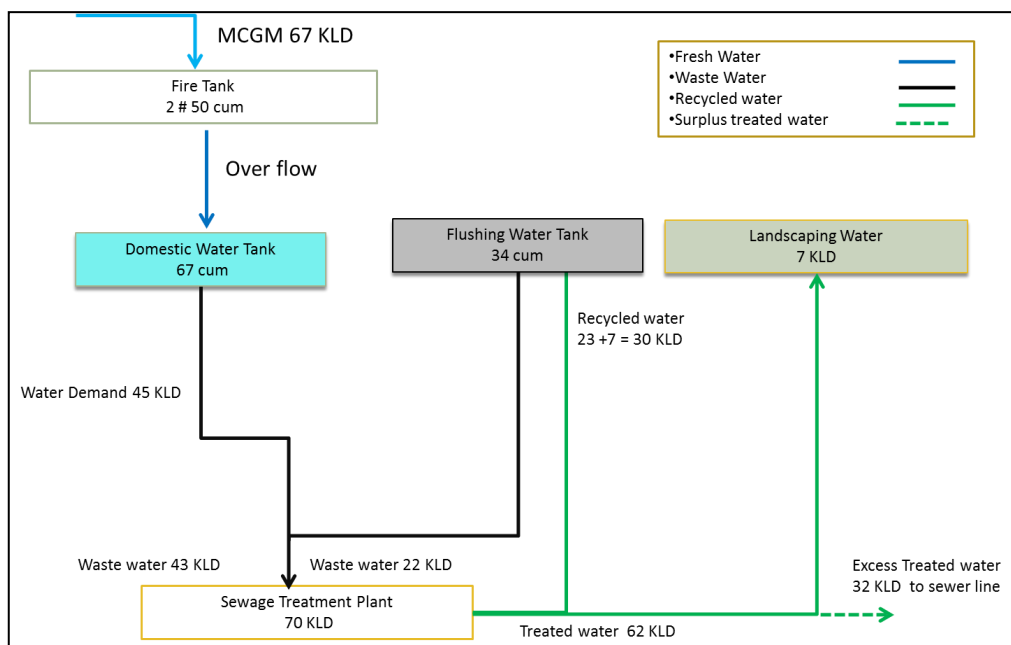
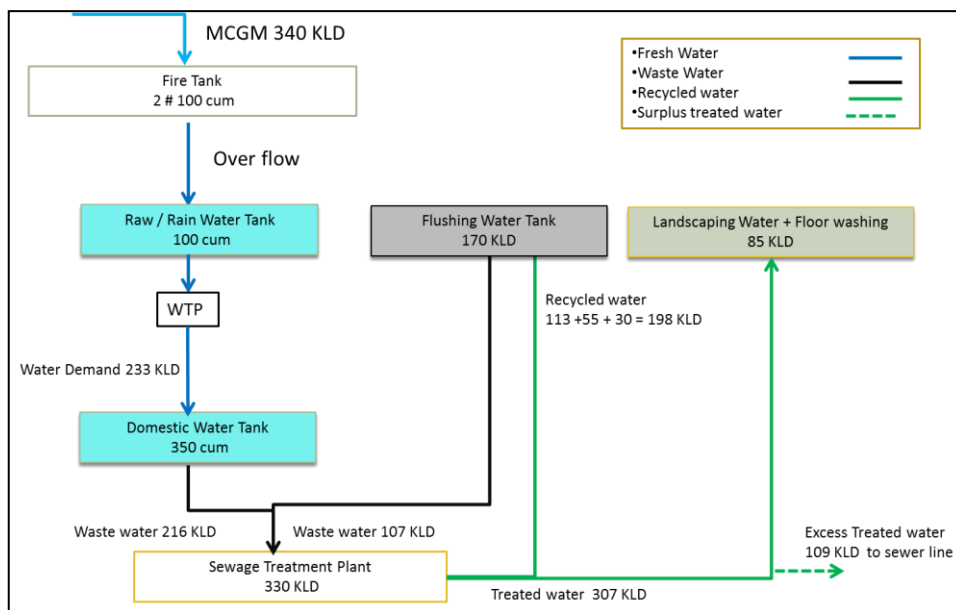

Fig. 3: Layout Plan

7 WATER, SOLID WASTE AND STORM WATER

The water requirement for the proposed project will be met from MCGM / Recycled water. The total water requirement for the proposed project is about 506 KLD. Sewage generated 388 KLD from the project on completion will be treated in STP and treated water shall be used for flushing and landscaping. Surplus treated water shall be disposed into existing MCGM sewer.



Solid waste generated will be segregated in Bio-degradable and Non-Bio-degradable. Onsite treatment for biodegradable waste has been proposed to convert this waste into organic manure with the help of Organic waste convertor.

Storm water from the entire plot will be collected through network of storm drains. Storm water from plot area will be then discharged in the MCGM storm water drain in the area.

8 FIRE FIGHTING MEASURES

For protection of the facility against fire, all the units will be equipped with any one or a combination of the following fire fighting systems:

1. Fire Fighting Tank
2. Fire Pump
3. Heat detector and smoke detectors.
4. Fire Detection & Alarm System.
5. Automatic Fire Sprinkler Systems
6. Hooters
7. Hose Reel
8. Fire Hydrant System
9. Portable Fire Extinguishers
10. Fire Engine Access Movement
11. Evacuation Plan

9 LANDSCAPING AND GREENBELT DEVELOPMENT

Total 12428.36 Sq.m areas has been proposed as a RG area. RG area is being divided in four parts. Two parts are proposed on podium and the rest of RG area has been kept on ground level.

Suitable plant species of local varieties will be planted with adequate spacing and density for their fast growth and survival. The plantation will be carried out during the construction phase.

10 Environmental Management Plan – Construction Phase

Sr.No	Media	Aspect	Mitigation measures	Implementation Schedule	Responsibility
1	Air	Dust emissions from excavation, demolition material handling and other construction activities.	Water Sprinkling on internal road 6.0 mt wide 800 Sq.m area with 1.8 cum water. Covered material storage area specifically for gravels and cement Phase wise demolition suggested to reduce the impact	Three times in peak construction activity in summer season Before construction activity storage area shall be constructed	Site Engineer Project Proponent/ Site Contractor
2	Noise	Noise generated from construction activities, operation of construction equipment and traffic.	Site Barricading upto 3.5 mt all around the proposed Building area Plantation along the proposed construction area as per the landscape plan	Prior construction activity proposed Buildings to of	Project Proponent/ Site Contractor
3	Water	Surface runoff from project site, Oil/fuel and waste spills, Improper debris disposal/sewage disposal	Sewage generated from construction labors for proposed building shall be treated in modular STP. Oil and grease traps for parking bays	Prior to start structure work (peak construction activity)	Site Engineer / Safety Officer
4	Land use and aesthetics	Land development	Green Belt development with 392 trees and 12411.91 Sq.m RG area	During Construction activity	Project Proponent
5	Soil	Construction activity leading to topsoil removal and erosion.	Excavation only for foundation for proposed buildings. Top soil shall be used for landscaping. Rest will be used for backfilling and leveling.	At the time of Foundation activity and site preparation	Site Engineer
6	Ecology, flora and fauna	Habitat disturbance during construction activity. Loss of vegetation.	No vegetation clearance required. Transplantation has already been done in amenity plot. Total 392 tree are estimated for plantation. Ecological important species shall be planted.	During Construction	Project Proponent

11 Environmental Management Plan – Operation Phase

Sr. No.	Media	Aspect	Mitigation measures	Implementation Schedule	Responsibility / Maintenance
1	Air	Vehicular Emission & Dust emission	Entry / Exit through 27.40 mt wide and 18.30 wide proposed DP road. Green Belt development along the road to reduce the air borne particles and to absorb the vehicular emissions	Before Handing over to end user	Project proponent
2	Noise	Noise from D.G sets, vehicle movement.	DG sets with acoustic enclosure. Maximum sound pressure level shall be 75 dB(A) at 1 meter from the enclosure surface as per the CPCB standards .	Before Handing over to end user	Project proponent
3	Water	Sewage Discharge to Sewer line/recycled after treatment as per PCB norms.	Total sewage generation shall be 393 KLD. STP has been provided with 400 KLD capacity. Monitoring of STP inlet and outlet at regular interval. Recycling of treated waste water for flushing and landscaping	Throughout the life cycle of project	First 3 years PP and then Society
4	Soil	Storage and disposal of solid waste, Discharge of sewage, Fuel and material spills, Pesticides use	Centralized mechanical composter with segregation area to process the Biodegradable waste for manure generation. Excess treated sewage 145 KLD shall be discharge in to municipal sewer drain	Before Handing over to users and throughout the life cycle of project	Project proponent / Housing society after 3 years
5	Ecology, flora and fauna	Change in land cover.	12411.91 Sq.m of RG area with 392 No's of trees (mainly local species)	At least 80% landscape development and tree plantation during Construction phase of the project	Project proponent
6	Socio-economy	Job opportunity	Job opportunity in form of security guard, housekeeping,, gardener STP operator etc within project Due to conversion of land use from Industrial to residential existing commercial activity shall be discontinue however there shall be no much impact	Socio-economy	Job opportunity

			on the people associated with these activity as most of the units are already moved to other place prior to proposed activity.		
--	--	--	--	--	--